



US 20200045450A1

(19) **United States**

(12) **Patent Application Publication**
MILOT et al.

(10) **Pub. No.: US 2020/0045450 A1**

(43) **Pub. Date: Feb. 6, 2020**

(54) **LOUDSPEAKER**

Publication Classification

(71) Applicant: **HARMAN INTERNATIONAL INDUSTRIES, INCORPORATED**, Stamford, CT (US)

(51) **Int. Cl.**
H04R 9/04 (2006.01)
H04R 1/02 (2006.01)
H04R 9/06 (2006.01)
H04R 9/02 (2006.01)

(72) Inventors: **Gilles MILOT**, Paris (FR); **Marc-Olivier CHAUVEAU**, Saint-Cyr-Sur-Loire (FR); **Ludovic FOURNIER**, Chateau du Loir (FR); **Guenther WEBER**, Kelheim (DE); **Armin PROMMERSBERGER**, Karlsbad (DE)

(52) **U.S. Cl.**
CPC *H04R 9/046* (2013.01); *H04R 9/027* (2013.01); *H04R 9/06* (2013.01); *H04R 1/023* (2013.01)

(73) Assignee: **HARMAN INTERNATIONAL INDUSTRIES, INCORPORATED**, Stamford, CT (US)

(57) **ABSTRACT**

(21) Appl. No.: **16/492,444**

A loudspeaker and method of operating a loudspeaker are provided. The loudspeaker has a motor assembly with at least one planar coil. First and second magnets are magnetized in a magnetized direction perpendicular to a direction of coil movement and perpendicular to a central axis of radiation of the loudspeaker. The central axis of radiation is generally parallel to a direction of coil movement and parallel to the plane of the planar coil. The first and second magnets each have upper and lower large surface faces separated by a narrowest dimension. The first and second magnets are magnetized across the narrowest dimension in first and second magnetized directions being opposite.

(22) PCT Filed: **Mar. 7, 2018**

(86) PCT No.: **PCT/US2018/021319**

§ 371 (c)(1),

(2) Date: **Sep. 9, 2019**

Related U.S. Application Data

(60) Provisional application No. 62/467,907, filed on Mar. 7, 2017.

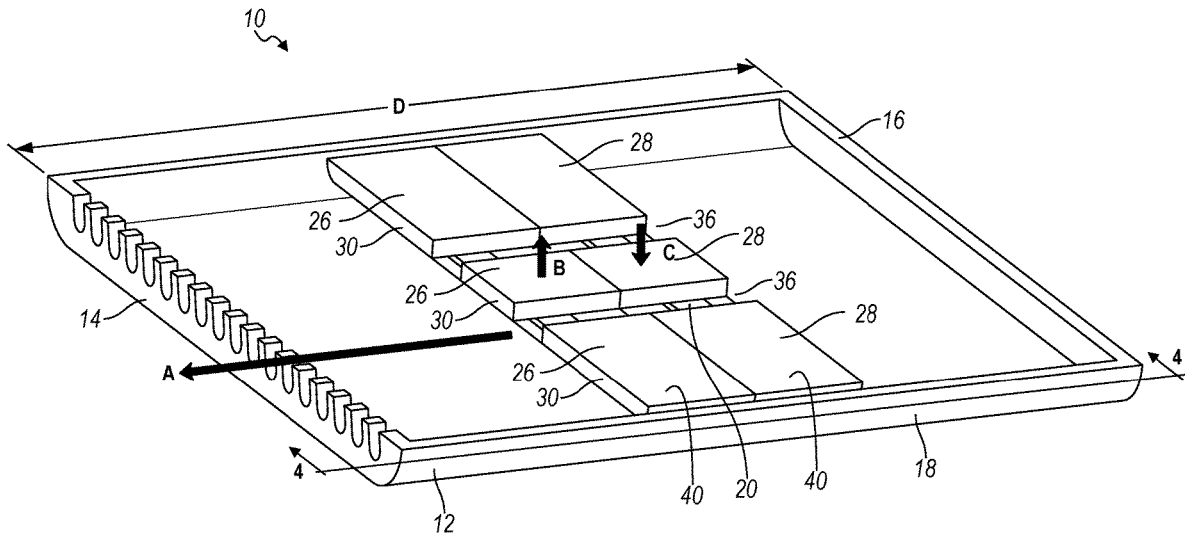

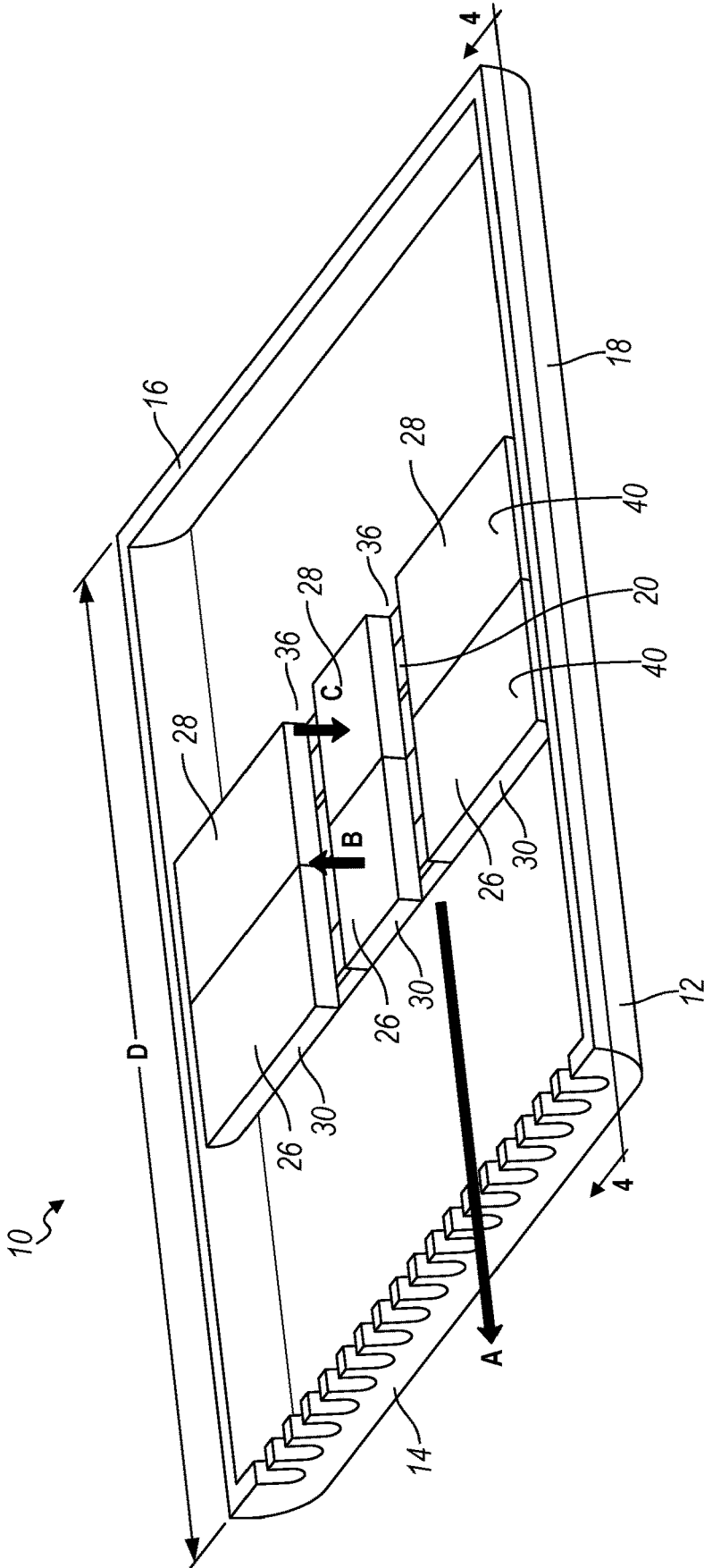

FIG. 1

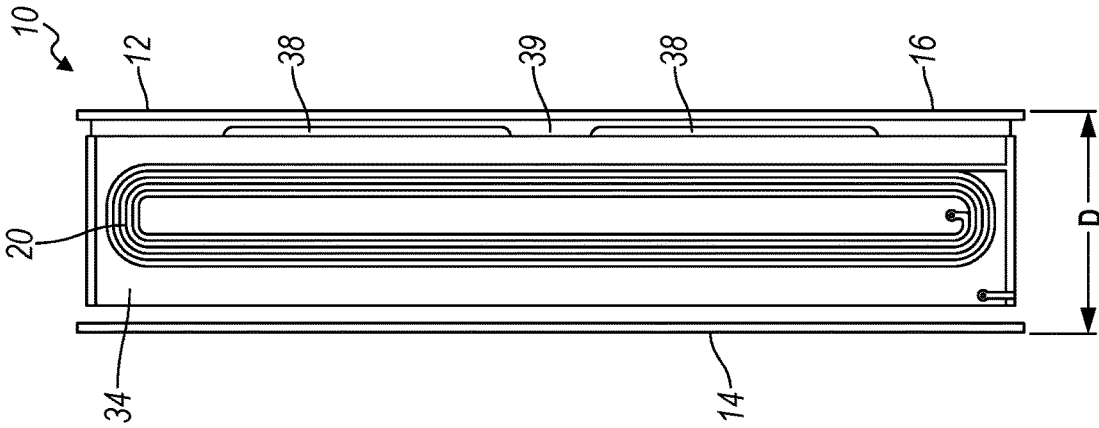

FIG. 5

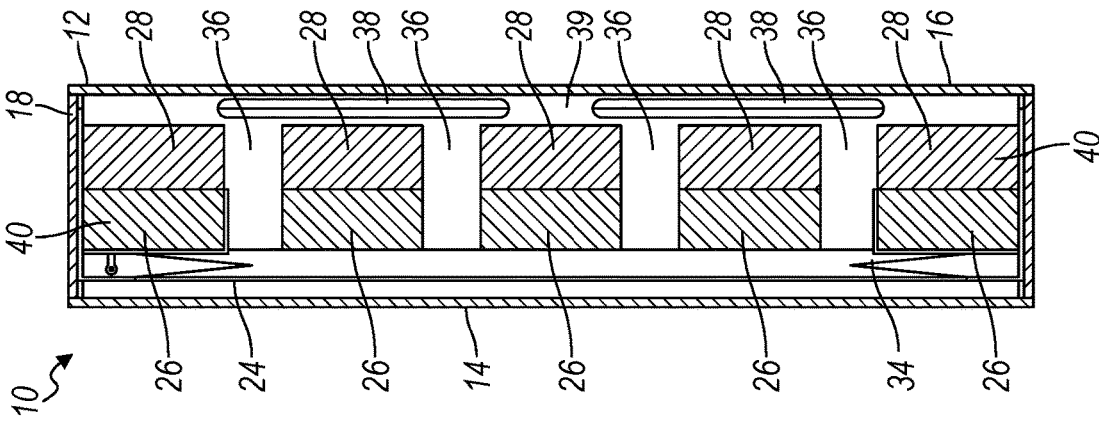

FIG. 4

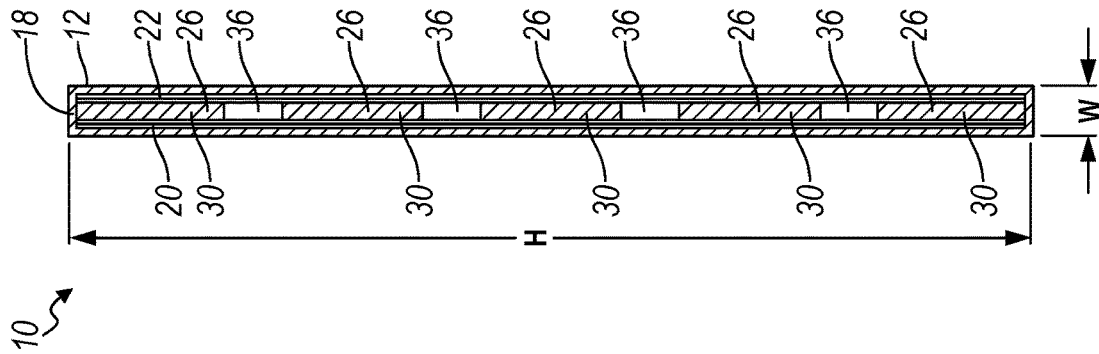

FIG. 3

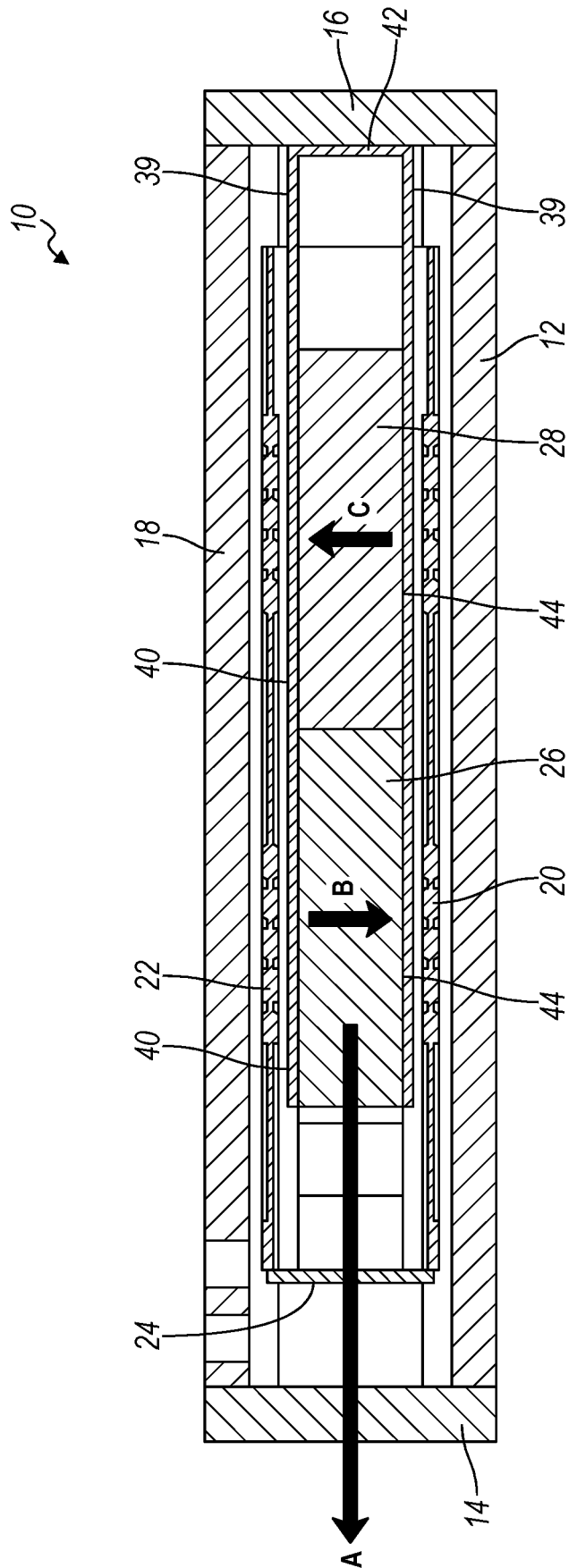

FIG. 6

LOUDSPEAKER

CROSS-REFERENCE TO RELATED APPLICATIONS

[0001] This application claims the benefit of U.S. provisional application Ser. No. 62/467,907 filed Mar. 7, 2017, the disclosure of which is hereby incorporated in its entirety by reference herein.

TECHNICAL FIELD

[0002] This application relates loudspeakers having a magnet and a moving-coil electrodynamic motor.

BACKGROUND

[0003] An electrodynamic motor in a loudspeaker includes a voice coil and a magnet assembly that generates a constant magnetic field. An alternating current corresponding to electrical signals conveying audio signals is provided to the voice coil. When current flows through the voice coil, the coil interacts with the constant magnetic field and results in movement of the voice coil. This interaction results in the force F , expressed as a product of the magnetic flux density B , the overall length of the voice coil's turns linked to the magnetic flux l , and the value of the electrical current running through the voice coil I , according to the formula $F=B \cdot I \cdot l$. Due to the force acting on the voice coil wire positioned in the constant magnetic field, the alternating current actuates the voice coil to moves back and forth and, accordingly, moves the diaphragm to which the voice coil (or coil former) is attached. The reciprocating diaphragm produces acoustic signals that propagate as sound waves through air.

[0004] One example of a moving coil loudspeaker is U.S. Pat. No. 9,100,738 by Harman International Industries.

SUMMARY

[0005] According to at least one embodiment, a loudspeaker is provided having a motor assembly with at least one planar coil. First and second magnets are magnetized in a magnetized direction perpendicular to a direction of coil movement and perpendicular to a central axis of radiation of the loudspeaker. The central axis of radiation is generally parallel to a direction of coil movement and parallel to the plane of the planar coil.

[0006] In another embodiment, the first and second magnets each have upper and lower large surface faces separated by a narrowest dimension. The first and second magnets are magnetized across the narrowest dimension in first and second magnetized directions being opposite. The planar coil is arranged in a plane along at least one of the upper and lower large surface faces, wherein a direction of coil movement is parallel to the plane of the coil.

[0007] In another embodiment, the narrowest magnet face dimension is less than five millimeters.

[0008] In another embodiment, the planar coil has first and second planar coils. The first and second planar coils are positioned in a plane parallel to and along the upper and lower large surfaces respectively.

[0009] In another embodiment, the first and second magnets each include at least two magnets spaced apart in a height direction by an air gap, wherein the height direction is perpendicular to the direction of coil movement and perpendicular to the narrowest magnet face dimension.

[0010] In another embodiment, the first and second magnets are arranged in-line between a front grill and a back wall. A depth of the loudspeaker is defined between the front grill and the back wall.

[0011] According to at least one other embodiment, a loudspeaker is provided having at least one coil. A first set of magnets is magnetized in a first magnetized direction. A second set of magnets is positioned adjacent the first set of magnets and is magnetized in a second magnetized direction being opposite the first magnetized direction. The first and second magnetized directions are perpendicular to direction of coil movement and perpendicular to an axis of radiation of the loudspeaker. The axis of radiation is generally parallel to the direction of coil movement.

[0012] In another embodiment, the loudspeaker has a front grill enclosing the loudspeaker through which the axis of radiation extends. The first and second magnetized directions are generally parallel to the front grill of the loudspeaker.

[0013] In another embodiment, the first set of magnets is positioned closer to the grill than the second set of magnets in the direction of coil movement.

[0014] In another embodiment, the first and second magnetized directions extend across a narrow magnet face having the narrowest magnet face dimension.

[0015] In another embodiment, the coil has first and second coil. The first and second coils are separated by the narrowest magnet face dimension.

[0016] In another embodiment, the second set of magnets are arranged adjacent to the first set of magnets in the direction of coil movement.

[0017] In another embodiment, the first and second set of magnets each include at least two magnets spaced apart in a height direction by an air gap.

[0018] In another embodiment, the loudspeaker has a diaphragm connected to the coil. The diaphragm is positioned closer to the first set of magnets than the second set of magnets.

[0019] According to at least one other embodiment, a method of operating a loudspeaker is provided. A motor assembly is provided having first and second magnets. Each of the first and second magnets has upper and lower large surface faces separated by a narrowest dimension. The first and second magnets are magnetized across the narrowest dimension in first and second magnetized directions being opposite. A first coil is positioned along at least one of the upper and lower large surfaces. The first coil is energized and in response, the first coil moves in a direction of coil movement being perpendicular to the first and second magnetized directions.

[0020] In another embodiment, the method includes arranging first and second magnets in-line in the direction of coil movement.

[0021] In another embodiment, the method includes positioning a second coil along at the other of the upper and lower large surfaces. The first and second coils are energized and in response to energizing, the first and second coils move in the direction of coil movement being perpendicular to the first and second magnetized directions.

BRIEF DESCRIPTION OF THE DRAWINGS

[0022] FIG. 1 is a perspective view of a portion of a loudspeaker according to one embodiment.

[0023] FIG. 2 is another perspective view of a portion of the loudspeaker of FIG. 1.

[0024] FIG. 3 is a cross-section view of the loudspeaker through section 3-3 of Figure of FIG. 2.

[0025] FIG. 4 is a cross-section view of the loudspeaker through section 4-4 of Figure of FIG. 2 showing a top view of the magnets.

[0026] FIG. 5 is a cross-section view of the loudspeaker through section 5-5 of Figure of FIG. 2 showing a top view of the coil.

[0027] FIG. 6 is a side cross-section view of the loudspeaker through section 6-6 of Figure of FIG. 2.

DETAILED DESCRIPTION

[0028] As required, detailed embodiments of the present invention are disclosed herein; however, it is to be understood that the disclosed embodiments are merely exemplary of the invention that may be embodied in various and alternative forms. The figures are not necessarily to scale; some features may be exaggerated or minimized to show details of particular components. Therefore, specific structural and functional details disclosed herein are not to be interpreted as limiting, but merely as a representative basis for teaching one skilled in the art to variously employ the present invention.

[0029] Loudspeakers generally include a motor having a magnet. The magnet has two poles that produce a magnetic field between the two poles. A moving coil is formed by turns of conductive coil. When current flows through the coil, the coil is subject to magnetic field and force is generated which results in movement of the coil. When current flows through the coil, the coil is subject to magnetic field and force is generated which results in movement of the coil in accordance with the formula $F=B \cdot I \cdot L$ (where B is the intensity of induction or magnetic field, I is the intensity of current and L is the length of the conductor subject to the magnetic field).

[0030] FIG. 1 illustrates a perspective view of a loudspeaker 10 with a portion of a housing removed in order to view the internal motor and magnet architecture. The housing 12 includes a front grill 14 having a plurality of apertures through which acoustic radiation radiates. The front grill 14 provides protection for other loudspeaker components. The housing 12 also includes a back wall 16 that encloses the rear of the loudspeaker 10. The depth D of the speaker 10 is defined between the front grill 14 and the back wall 16. In one embodiment, the depth D of the loudspeaker 10 may range from 10-25 mm. However other depth dimensions may be possible.

[0031] The housing 12 may also have a frame 18 that defines side walls of the loudspeaker 10 and connects the front grill 14 to the back wall 16. As shown in the Figures, the frame 18 may be generally cylindrical and have an elongated oval, or race-track cross section with circular ends connecting elongated sides. In other embodiments, the frame may be elliptical or circular shaped. However, any suitable frame shape may be used.

[0032] The loudspeaker 10 includes at least one moving coil 20 connected to a diaphragm 24. The coil 20 moves in direction indicated by arrow A. The direction of movement is generally perpendicular to the front grill 14.

[0033] The loudspeaker 10 includes planar magnets that are magnetized in direction being perpendicular to the motion of the coil. As shown in FIG. 1, the loudspeaker 10

has a first magnet 26, or set of magnets. The first magnets 26 are magnetized in a direction B being perpendicular to the direction of coil motion A. The loudspeaker 10 has a second magnet 28, or second set of magnets abutting the first magnets 26 and magnetized in a direction C, opposite direction B and also perpendicular to the direction of coil motion A. The magnets 26, 28 are oriented with the smallest face 30 parallel to the front grill 14 and perpendicular to direction A and the movement of the coil 20.

[0034] The loudspeaker 10 may have more than one coil. For example, FIG. 2 illustrates another perspective view of the loudspeaker 10, similar to FIG. 1 but where two moving coils 20 are shown. A first coil 20 is positioned on one side of the magnets 26, 28 and a second coil 22 is positioned on an opposite side of the magnets 26, 28.

[0035] FIG. 3 is a cross-section view of the loudspeaker 10 through section 3-3 of Figure of FIG. 2. As shown in FIG. 3, the magnets 26, 28 are positioned between the two coils 20, 22. The speaker has a narrow width W since the coils are separated by the smallest dimension 30 of the magnets 26, 28. The width W of the speaker, and consequently the grill opening 14, may be approximately 3 mm. The speaker 10 and grill opening 14 may have a height H defined between the side walls being approximately 30 mm to 60 mm. The width W and height H may be other suitable dimensions based on speaker characteristics.

[0036] FIG. 4 is a cross-section view of the loudspeaker 10 through section 4-4 of Figure of FIG. 1 showing a top view of the magnets 26, 28 and the loudspeaker 10. The diaphragm 24 is connected to the coils through a former 34 (the coils are not shown in this view). In order to convert force moving the coil 20, 22 into an acoustic pressure wave, the diaphragm 24 is connected and can move the air with the enclosure.

[0037] The spaces 36 between the magnets 26, 28 allow for air flow as the coils 20, 22 and diaphragm 24 move. The first magnets 26 are positioned parallel and closer to the diaphragm 24. The second magnets 28 are positioned adjacent to the magnets 26 and closer to the back wall 16.

[0038] FIG. 5 is a cross-section view of the loudspeaker 10 through section 5-5 of Figure of FIG. 2 showing a top view of one coil 20. The coils 20, 22 are planar coils oriented parallel to the largest surface 40, 44 of the magnets in order to optimize magnet efficiency since the efficiency of neodymium magnets depends on the surface area. This configuration of magnets and coils also optimizes the force factor (BL factor) for a thin loudspeaker and improves that sound pressure level (SPL) for the same sized driver.

[0039] FIG. 6 is a side cross-section view of the loudspeaker 10 through section 6-6 of Figure of FIG. 2. As shown in FIG. 6, the magnets 26, 28 are sandwiched between pole pieces 39. As shown in FIG. 6, the pole piece 39 may be a continuous yoke that extends from a first face 40 of the magnets 26, 28 to a back connecting plate 42 adjacent the back wall 16 and then extends along a second face 44 of the magnets 26, 28. The pole piece 39 is generally formed of iron or low carbon content steel. The pole piece 39 may have openings 38 for therein which provide air flow.

[0040] The speaker 10 may have coils 20, 22 positioned on each side of the magnets 26, 28. The coils 20, 22 are positioned outboard of the pole pieces 39. In another embodiment, the speaker 10 may only have one coil 20 disposed on one side of the magnets 26, 28. The coils 20, 22 are connected to the diaphragm 24 and move in a direction

A. In another embodiment, it is possible to have more than one or multiple coils **20**, **22** positioned on one side or both side of the magnet **26**, **28**.

[0041] As shown in FIG. 6, the first magnets **26** are magnetized in a direction B being perpendicular to the direction of coil motion A. The second magnets **28** are magnetized in a direction C, opposite direction B and also perpendicular to the direction of coil motion A. The magnets **26**, **28** are magnetized in a direction between the largest faces **40**, **44**. The magnets **26**, **28** are magnetized across the smallest dimension **30**.

[0042] While exemplary embodiments are described above, it is not intended that these embodiments describe all possible forms of the invention. Rather, the words used in the specification are words of description rather than limitation, and it is understood that various changes may be made without departing from the spirit and scope of the invention. Additionally, the features of various implementing embodiments may be combined to form further embodiments of the invention.

What is claimed is:

1. A loudspeaker comprising:

a motor assembly having at least one planar coil; and first and second magnets magnetized in a magnetized direction perpendicular to a direction of coil movement and perpendicular to a central axis of radiation of the loudspeaker; and

wherein the central axis of radiation is generally parallel to a direction of coil movement and parallel to the plane of the planar coil.

2. The loudspeaker of claim 1 wherein the first and second magnets each have upper and lower large surface faces separated by a narrowest dimension, wherein the first and second magnets are magnetized across the narrowest dimension in first and second magnetized directions being opposite,

wherein the at least one planar coil is arranged in a plane along at least one of the upper and lower large surface faces, wherein a direction of coil movement is parallel to the plane of the coil.

3. The loudspeaker of claim 2, wherein the narrowest dimension is less than five millimeters.

4. The loudspeaker of claim 2, wherein the at least one planar coil comprises first and second planar coils, wherein the first and second planar coils are positioned in a plane parallel to and along the upper and lower large surfaces respectively.

5. The loudspeaker of claim 1, wherein the first and second magnets each include at least two magnets spaced apart in a height direction by an air gap, wherein the height direction is perpendicular to the direction of coil movement and perpendicular to the narrowest magnet dimension.

6. The loudspeaker of claim 1, wherein the first and second magnets are arranged in-line between a front grill and a back wall, wherein a depth of the loudspeaker is defined between the front grill and the back wall.

7. A loudspeaker comprising:

at least one coil;

a first set of magnets magnetized in a first magnetized direction;

a second set of magnets positioned adjacent the first set of magnets and magnetized in a second magnetized direction being opposite the first magnetized direction;

wherein the first and second magnetized directions are perpendicular to direction of coil movement and perpendicular to an axis of radiation of the loudspeaker, wherein the axis of radiation is generally parallel to the direction of coil movement.

8. The loudspeaker of claim 7, further comprising a front grill of the loudspeaker enclosing the loudspeaker through which the axis of radiation extends, wherein the first and second magnetized directions are generally parallel to the front grill of the loudspeaker.

9. The loudspeaker of claim 8, wherein the first set of magnets is positioned closer to the grill than the second set of magnets in the direction of coil movement.

10. The loudspeaker of claim 7, wherein the first and second magnetized directions extend across a narrow magnet face having the narrowest magnet face dimension.

11. The loudspeaker of claim 10, wherein narrowest magnet face dimension is less than five millimeters.

12. The loudspeaker of claim 7, wherein the at least one coil comprises first and second coils, wherein the first and second coils are separated by the narrowest magnet face dimension.

13. The loudspeaker of claim 7, wherein the second set of magnets are arranged adjacent to the first set of magnets in the direction of coil movement.

14. The loudspeaker of claim 7, wherein the first and second set of magnets each include at least two magnets spaced apart in a height direction by an air gap.

15. The loudspeaker of claim 7, wherein first set of magnets are arranged in-line with the second set of magnets between a front grill and a back wall, wherein a depth of the loudspeaker is defined between the front grill and the back wall.

16. The loudspeaker of claim 7, further comprising a diaphragm connected to the coil, wherein the diaphragm is positioned closer to the first set of magnets than the second set of magnets.

17. A method of operating a loudspeaker comprising: providing a motor assembly having first and second magnets each having upper and lower large surface faces separated by a narrowest dimension, wherein the first and second magnets are magnetized across the narrowest dimension in first and second magnetized directions being opposite;

positioning a first coil along at least one of the upper and lower large surfaces;

energizing the first coil,

wherein in response to energizing, the first coil moves in a direction of coil movement being perpendicular to the first and second magnetized directions.

18. The method of claim 17, further comprising arranging first and second magnets in-line in the direction of coil movement.

19. The method of claim 17, wherein narrowest dimension is less than five millimeters.

20. The method of claim 17, further comprising:

positioning a second coil along at the other of the upper and lower large surfaces; and

energizing the first and second coils,

wherein in response to energizing, the first and second coils move in the direction of coil movement being perpendicular to the first and second magnetized directions.

* * * * *